

Inline filter with filter element according to DIN 24550

Type 50LEN0040 to 0400; 50LE0130, 0150

RE 51447

Issue: 2019-12

Replaces: 11.14



HAD8041_14

- ▶ Size according to **DIN 24550**: 0040 to 0400
- ▶ additional sizes: 0130, 0150
- ▶ Nominal pressure 50 bar [725 psi]
- ▶ Connection up to 1 1/2"
- ▶ Operating temperature -10 °C to 100 °C [14 °F to 212 °F]

Features

Inline filters are used in hydraulic systems for separating solid materials from the fluids and lubricating oils. They are intended for attachment in pipelines.

They distinguish themselves by the following:

- ▶ Filters for inline installation
- ▶ Special highly efficient filter materials
- ▶ Filtration of very fine particles and high dirt holding capacity across a broad pressure differential range
- ▶ High collapse resistance of the filter elements
- ▶ By default equipped with mechanical optical maintenance indicator with memory function
- ▶ Available as an option with different electronic switching elements, modular design
- ▶ Optional bypass valve integrated in the filter housing

Contents

Features	1
Ordering code filter	2, 3
Preferred types	4
Ordering code accessories	5
Symbols	6
Function, section	7
Technical data	8, 9
Compatibility with hydraulic fluids	9
Characteristic curves	10 ... 12
Dimensions	13
Maintenance indicator	14
Ordering code spare parts	15 ... 17
Assembly, commissioning, maintenance	18
Tightening torques	19
Directives and standardization	19, 20

Ordering code filter

01	02	03	04	05	06	07	08	09	09
50LE			-		-	-	-	-	-

Series

01	Inline filter 50 bar [725 psi]	50LE
----	--------------------------------	------

Filter element

02	with filter element according to DIN 24550	N
----	---	---

Size

03	LEN... (Filter element according to DIN 24550)	0040 0063 0100 0160 0250 0400
	LE... (Filter element according to Bosch Rexroth standard)	0130 0150

Filter rating in µm

04	Nominal Stainless steel wire mesh, cleanable	G10 G25 G40 G60 G100
	Nominal Filter paper, not cleanable	P10 P25
	Absolute (ISO 16889; $\beta_{x(c)} \geq 200$) Non-woven glass fiber media, not cleanable	PWR3 PWR6 PWR10 PWR20

Pressure differential

05	max. admissible pressure differential of the filter element 30 bar [435 psi], with bypass valve	A00
	max. admissible pressure differential of the filter element 330 bar [4786 psi], without bypass valve	B00

Maintenance indicator

06	Maintenance indicator, mech./optical, switching pressure 0.8 bar [11.6 psi] – bypass cracking pressure 2.5 bar [36 psi]	V0.8
	Maintenance indicator, mech./optical, switching pressure 1.5 bar [21.8 psi] – bypass cracking pressure 2.5 bar [36 psi]	V1.5
	Maintenance indicator, mech./optical, switching pressure 2.2 bar [32 psi] – bypass cracking pressure 3.5 bar [51 psi]	V2.2
	Maintenance indicator, mech./optical, switching pressure 5.0 bar [72.5 psi] – bypass cracking pressure 7 bar [102 psi]	V5,0

Seal

07	NBR seal	M
	FKM seal	V

Connection

08	Frame size	0040-0100	0130-0150	0160-0400		
	Connection					
	G 3/4	●			Pipe thread according to ISO 228	R3
	G 1		●			R4
	G 1 1/2			●		R6
	SAE 12	X			Pipe thread according to SAE J1926	U4
	SAE 16		X			U9
SAE 24			X	U6		
	<input checked="" type="checkbox"/> Standard connection <input type="checkbox"/> Alternative connection					

Ordering code filter

01	02	03		04	05		06	07		08		09		09
50LE			-			-		-		-		-		

Supplementary information

09	without bypass valve (only possible in connection with filter element version "A00") ¹⁾	NB
	Manufacturer's inspection certificate M according to DIN 55350 T18	Z1

¹⁾ **Attention:** If this option is selected and the maintenance indicator is not observed, the filter element may collapse in case of operating pressures of more than 30 bar [435 psi].

Order example:

50LEN0100-PWR3A00-V5,0-M-R4

Further versions (filter materials, connections,...) are available on request.

Preferred types**NBR seal, with bypass, flow specifications for 30 mm²/s [143 SUS]**Inline filter 50 LE(N), filter rating **3 µm**

Type	Flow in l/min [gpm] at Δp = 1 bar [14.5 psi]	Material no. Filter				Material no. Replacement filter element
		..R3	R928048449	..U4	R928048452	
50LEN0040-PWR3A00-V2,2-M-..	23 [6.08]	..R3	R928048449	..U4	R928048452	R928006645
50LEN0063-PWR3A00-V2,2-M-..	30 [7.93]	..R3	R928050995	..U4	R928048453	R928006699
50LEN0100-PWR3A00-V2,2-M-..	44 [11.62]	..R3	R928051075	..U4	R928048454	R928006753
50LE0130-PWR3A00-V2,2-M-..	74 [19.55]	..R4	R928050770	..U9	R928048455	R928022274
50LE0150-PWR3A00-V2,2-M-..	89 [23.51]	..R4	R928050850	..U9	R928048456	R928022283
50LEN0160-PWR3A00-V2,2-M-..	132 [34.87]	..R6	R928051152	..U6	R928048457	R928006807
50LEN0250-PWR3A00-V2,2-M-..	190 [50.19]	..R6	R928051232	..U6	R928048458	R928006861
50LEN0400-PWR3A00-V2,2-M-..	250 [66.04]	..R6	R928051312	..U6	R928048459	R928006915

Inline filter 50 LE(N), filter rating **6 µm**

Type	Flow in l/min [gpm] at Δp = 1 bar [14.5 psi]	Material no. Filter				Material no. Replacement filter element
		..R3	R928050930	..U4	R928050931	
50LEN0040-PWR6A00-V5,0-M-..	31 [8.19]	..R3	R928050930	..U4	R928050931	R928006646
50LEN0063-PWR6A00-V5,0-M-..	46 [12.15]	..R3	R928051008	..U4	R928051009	R928006700
50LEN0100-PWR6A00-V5,0-M-..	57 [15.06]	..R3	R928051088	..U4	R928051089	R928006754
50LE0130-PWR6A00-V5,0-M-..	94 [24.83]	..R4	R928050783	..U9	R928050784	R928022275
50LE0150-PWR6A00-V5,0-M-..	103 [27.21]	..R4	R928050863	..U9	R928050864	R928022284
50LEN0160-PWR6A00-V5,0-M-..	175 [46.23]	..R6	R928051165	..U6	R928051166	R928006808
50LEN0250-PWR6A00-V5,0-M-..	226 [59.70]	..R6	R928051245	..U6	R928051246	R928006862
50LEN0400-PWR6A00-V5,0-M-..	282 [74.50]	..R6	R928051325	..U6	R928051326	R928006916

Inline filter 50 LE(N), filter rating **10 µm**

Type	Flow in l/min [gpm] at Δp = 1 bar [14.5 psi]	Material no. Filter				Material no. Replacement filter element
		..R3	R928047959	..U4	R928048460	
50LEN0040-PWR10A00-V2,2-M-..	36 [9.51]	..R3	R928047959	..U4	R928048460	R928006647
50LEN0063-PWR10A00-V2,2-M-..	69 [18.23]	..R3	R928050967	..U4	R928048461	R928006701
50LEN0100-PWR10A00-V2,2-M-..	75 [19.81]	..R3	R928051047	..U4	R928048462	R928006755
50LE0130-PWR10A00-V2,2-M-..	127 [33.55]	..R4	R928050743	..U9	R928048463	R928022276
50LE0150-PWR10A00-V2,2-M-..	150 [39.63]	..R4	R928050822	..U9	R928048464	R928022285
50LEN0160-PWR10A00-V2,2-M-..	210 [55.48]	..R6	R928051125	..U6	R928048465	R928006809
50LEN0250-PWR10A00-V2,2-M-..	260 [68.68]	..R6	R928051204	..U6	R928048466	R928006863
50LEN0400-PWR10A00-V2,2-M-..	300 [79.25]	..R6	R928051284	..U6	R928048467	R928006917

Ordering code accessories

(dimensions in mm [inch])

Electronic switching element for maintenance indicators

01	02	03
WE	-	-

Maintenance indicator

01	electronic switching element	WE
----	------------------------------	-----------

Type of signal

02	1 switching point	1SP
	2 switching points, 3 LED	2SP
	2 switching points, 3 LED and signal suppression up to 30 °C [86 °F]	2SPSU

Connector

03	Round plug-in connection M12 x 1, 4-pole	M12 x 1
	Rectangular plug-in connection, 2-pole, design A according to EN-175301-803	EN175301-803

Material numbers of the electronic switching elements

Material no.	Type	Signal	Switching points	Connector	LED
R928028409	WE-1SP-M12 x 1	Changeover	1	M12 x 1	No
R928028410	WE-2SP-M12 x 1	Normally open (at 75%) / normally closed contact (at 100%)	2		3 pieces
R928028411	WE-2SPSU-M12 x 1		1		
R928036318	WE-1SP-EN175301-803	Normally closed contact	1	EN 175301-803	No

Mating connectors according to IEC 60947-5-2

for electronic switching element with round plug-in connection M12 x 1

Mating connector suitable for K24 4-pole, M12 x 1 with screw connection, cable gland Pg9.

Material no. R900031155

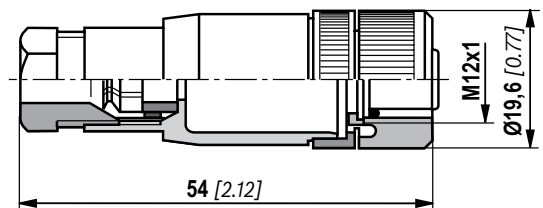

Mating connector suitable for K24-3m 4-pole, M12 x 1 with potted-in PVC cable, 3 m long.

Line cross-section: 4 x 0.34 mm²

Core marking: **1** brown **2** white
 3 blue **4** black

Material no. R900064381

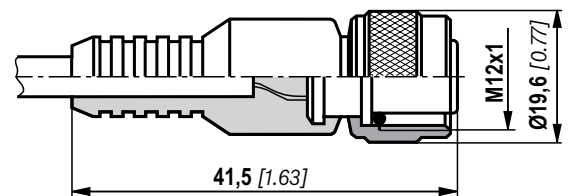

For more round plug-in connections and technical data refer to data sheet 08006.

Order example:

Inline filter with mechanical optical maintenance indicator for $p_{nom.} = 50 \text{ bar}$ [725 psi] with bypass valve, size 0160, with filter element 10 µm and electronic switching element M12 x 1 with 1 switching point for hydraulic fluid mineral oil HLP according to DIN 51524.

Filter with mech. optical maintenance indicator: 50LEN0160-PWR10A00-V5,0-M-R6

Material no. R928051126

Switching element: WE-1SP-M12 x 1

Material no. R928028409

Mating connector: Mating connector suitable for K24 4-pole, M12 x 1 with screw connection, cable gland Pg9. Material no. R900031155

Symbols

Inline filter with bypass and mechanical indicator

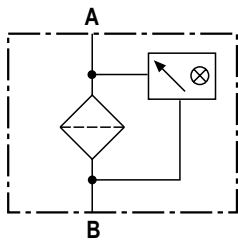
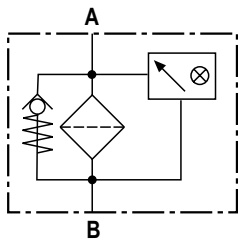

Inline filter without bypass and with mechanical indicator

Electronic switching element for maintenance indicator

Switching element Connector

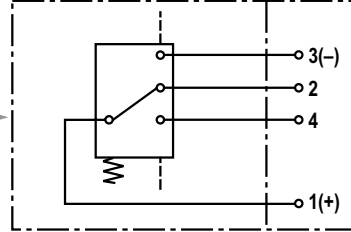

WE-1SP-M12 x 1

Switching element Connector

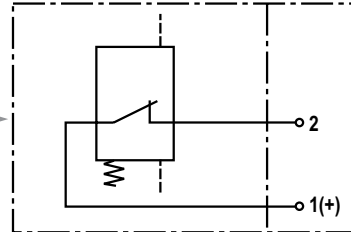

WE-1SP-EN175301-803

Switching element Connector

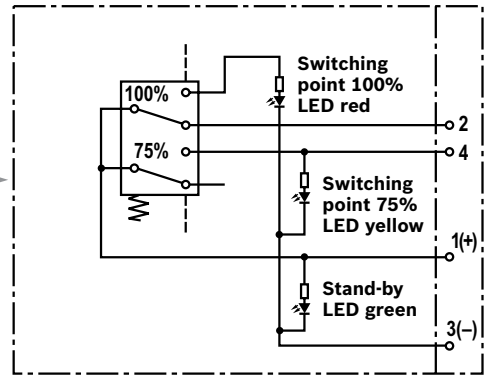

WE-2SP-M12 x 1

Circuit diagram drawn in plugged condition (operating state)

Switching element Connector

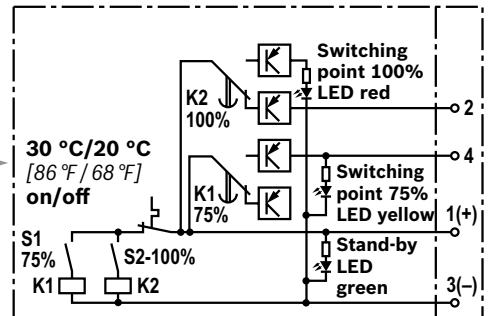

WE-2SPSU-M12 x 1

Circuit diagram drawn in plugged condition at temperature > 30 °C [86 °F] (operating state)

Function, section

The 50LE(N) inline filter is suitable for direct installation into pressure lines. It is installed upstream components to be protected.

It basically consists of filter head (1), a screwable filter bowl (2), filter element (3) as well as mechanical optical maintenance indicator (4). In case of filters with low-pressure-differential-stable filter elements (= code letter pressure differential A), there is an assembled bypass valve (5) as standard.

The installed spring (6) prevents possible vibrations of the filter element (3). During disassembly, the contact pressure of the spring (6) holds the filter element in the filter bowl (2).

Via the inlet, the fluid reaches the filter element (3) where it is cleaned. The dirt particles filtered out settle in the filter element (3). Via the outlet, the filtered fluid enters the hydraulic circuit.

The filter housing and all connection elements are designed so that pressure peaks - as they may e.g. occur in case of abrupt opening of large control valves due to the accelerated fluid quantity - can be securely absorbed. As of size 0160, the standard equipment comprises a drain screw (7).

By default, the filter is equipped with mechanical optical maintenance indicator (4). The electronic switching element (8) which has to be ordered separately is attached to the mechanical optical maintenance indicator (4) and held by means of a locking ring.

The electronic switching elements with 1 or 2 switching points are connected via a mating connector according to IEC-60947-5-2 or via a cable connection according to EN17301-803.

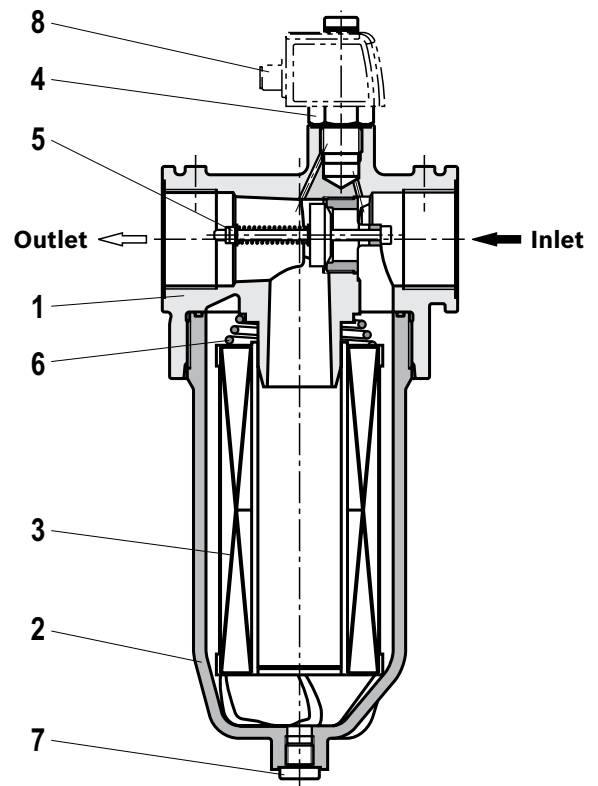

Type 50LEN0160

WARNING!

If the maintenance indicator is not observed while the element is exchanged, the bypass valve will open if the pressure differential increases. This means that part of the volume flow enters unfiltered into the clean side of the filter. Effective filtration is therefore no longer guaranteed.

Technical data

(For applications outside these parameters, please consult us!)

General					
Installation position		vertical			
Ambient temperature range		°C [°F] -10 ... +100 [14 ... +212] (shortly up to -30 [-22])			
Weight	NS	0040	0063	0100	0130
	kg [lbs]	1.05 [2.3]	1.1 [2.4]	1.2 [2.6]	1.91 [4.2]
	NS	0150	0160	0250	0400
	kg [lbs]	2.06 [4.5]	3.1 [6.8]	3.3 [7.3]	3.8 [8.4]
Volume	NS	0040	0063	0100	0130
	l [US gal]	0.27 [0.07]	0.39 [0.1]	0.58 [0.15]	0.89 [0.23]
	NS	0150	0160	0250	0400
	l [US gal]	1.1 [0.29]	1.31 [0.35]	1.89 [0.50]	2.84 [0.75]
Material	- Filter head	Aluminum			
	- Filter bowl	Aluminum			
	- Bypass valve	Aluminum / steel / POM			
	- Seals	NBR or FKM			
	- optical maintenance indicator	V0,8; V1,5; V2,2	Aluminum		
		V5,0	Brass		
Electronic switching element		Plastic PA6			

Hydraulic			
Maximum operating pressure	bar [psi]	50 [725]	
Hydraulic fluid temperature range	°C [°F]	-10 to +100 [+14 to +212]	
Minimum conductivity of the medium	pS/m	300	
Fatigue strength according to ISO 10771	Load cycles	> 10 ⁶ with max. operating pressure	
Type of pressure measurement of the maintenance indicator		Pressure differential	
Assignment: Response pressure of the maintenance indicator / cracking pressure of the bypass valve	bar [psi]	Response pressure of the maintenance indicator	Cracking pressure of the bypass valve
		0.8 ± 0.15 [11.6 ± 2.2]	2.5 ± 0.25 [36.3 ± 3.6]
		1.5 ± 0.20 [21.8 ± 2.9]	2.5 ± 0.25 [36.3 ± 3.6]
		2.2 ± 0.30 [31.9 ± 4.4]	3.5 ± 0.35 [50.8 ± 5.1]
		5.0 ± 0.50 [72.5 ± 7.3]	7.0 ± 0.5 [101.5 ± 7.3]
Filtration direction		From the outside to the inside	

Electric (electronic switching element)					
Electrical connection	Version	Round plug-in connection M12 x 1, 4-pole			Standard connection EN 175301-803
		WE-1SP-M12 x 1	WE-2SP-M12 x 1	WE-2SPSU-M12 x 1	WE-1SP-EN175301-803
Contact load, direct voltage	A _{max.}	1			
Voltage range	V _{max.}	150 (AC/DC)	10-30 (DC)		250 (AC)/200 (DC)
max. switching power with resistive load	W	20			70
Switching type	- 75% signal	-	Normally open contact		-
	- 100% signal	Changeover	Normally closed contact		Normally closed contact
	- 2SPSU			Signal interconnection at 30 °C [86 °F], return switching at 20 °C [68 °F]	
Display via LEDs in the electronic switching element 2SP...			Stand-by (LED green); 75% switching point (LED yellow) 100% switching point (LED red)		
Protection class according to EN 60529		IP 67			IP 65
Ambient temperature range		°C [°F] -25 to +85 [-13 to +185]			
For direct voltage above 24 V, spark extinguishing is to be provided for protecting the switching contacts.					
Weight	electronic switching element: - with round plug-in connection M12 x 1	kg [lbs]	0.1 [0.22]		

Technical data

(For applications outside these parameters, please consult us!)

Filter element			
Non-woven glass fiber media PWR...		Single-use element on the basis of inorganic fiber	
		Filtration ratio according to ISO 16889 up to $\Delta p = 5 \text{ bar}$ [72.5 psi]	Achievable oil cleanliness according to ISO 4406 [SAE-AS 4059]
	PWR20	$\beta_{20}(c) \geq 200$	19/16/12 – 22/17/14
	PWR10	$\beta_{10}(c) \geq 200$	17/14/10 – 21/16/13
	PWR6	$\beta_6(c) \geq 200$	15/12/10 – 19/14/11
	PWR3	$\beta_3(c) \geq 200$	13/10/8 – 17/13/10
Admissible pressure differential	– A	bar [psi]	30 [435]
	– B	bar [psi]	330 [4785]

Compatibility with hydraulic fluids

Hydraulic fluid	Classification	Suitable sealing materials	Standards
Mineral oil	HLP	NBR	DIN 51524
Biodegradable	– insoluble in water	HETG	VDMA 24568
		HEES	
	– soluble in water	HEPG	VDMA 24568
Flame-resistant	– water-free	HFDU, HFDR	VDMA 24317
	– containing water	HFAS	DIN 24320
		HFAE	
		HFC	
		NBR	VDMA 24317



Important information on hydraulic fluids!

- For more information and data on the use of other hydraulic fluids, please refer to data sheet 90220 or contact us!
- **Flame-resistant – containing water:** due to possible chemical reactions with materials or surface coatings of machine and system components, the service life with these hydraulic fluids may be less than expected. Filter materials made of filter paper P

(cellulose) may not be used, filter elements with filter materials made of glass fiber (HydroClean PWR... or wire mesh G) have to be used instead.

- **Biodegradable:** If filter materials made of filter paper are used, the filter life may be shorter than expected due to material incompatibility and swelling.

Characteristic curves PWR3

(measured with mineral oil HLP46 according to DIN 51524 at T = 40 °C) [104 °F]

Spec. weight: < 0.9 kg/dm³ Δp -Q-characteristic curves for complete filters recommended initial Δp for design = 1 bar [14.5 psi]

Selection of the perfect filter is made possible by our online "Bosch Rexroth FilterSelect" design software.

Oil viscosity:
 ——— 140 mm²/s [649 SUS]
 - · - · 68 mm²/s [315 SUS]
 - - - 30 mm²/s [143 SUS]

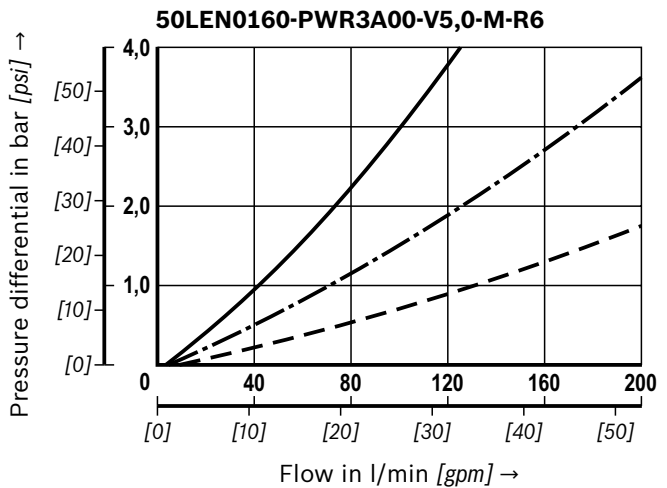
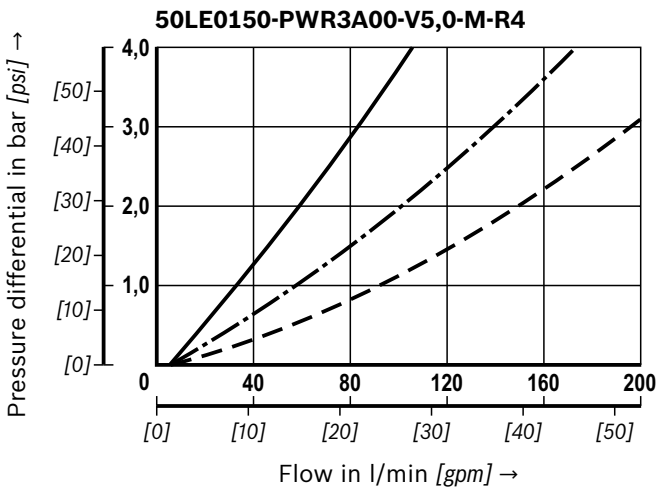
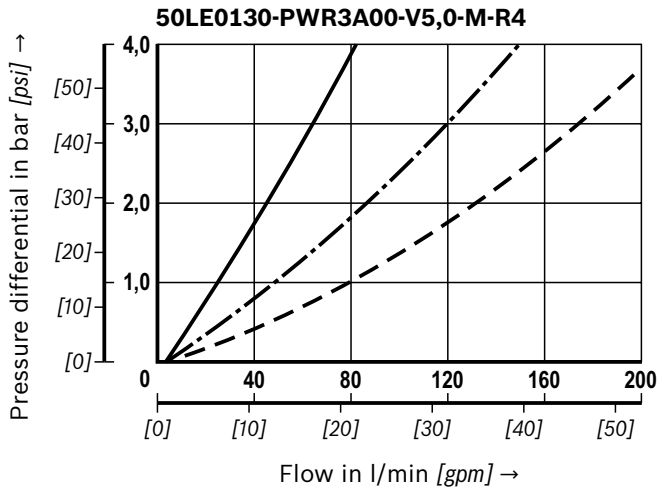
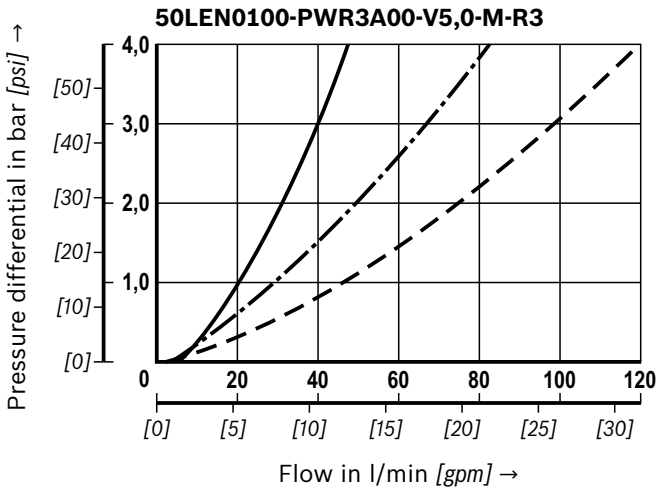
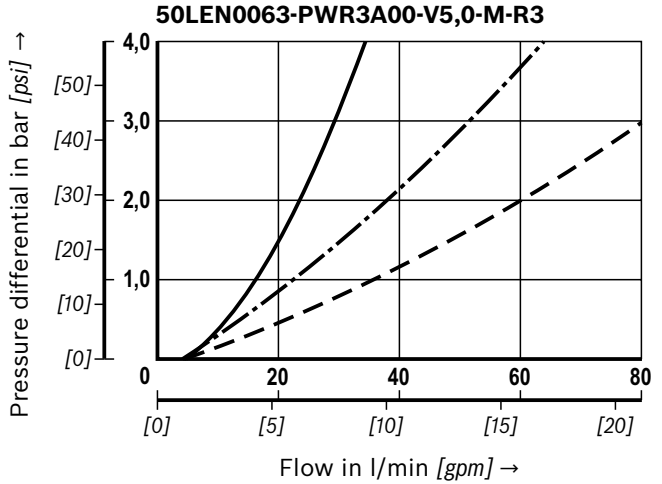
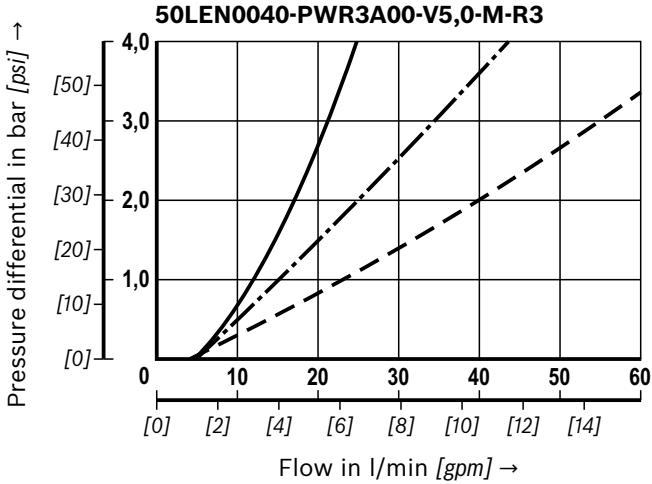

Characteristic curves PWR3; PWR10

(measured with mineral oil HLP46 according to DIN 51524 at T = 40 °C) [104 °F])

Spec. weight: < 0.9 kg/dm³ Δp -Q-characteristic curves for complete filters recommended initial Δp for design = 1 bar [14.5 psi]

Selection of the perfect filter is made possible by our online "Bosch Rexroth FilterSelect" design software.

Oil viscosity:
 ——— 140 mm²/s [649 SUS]
 - · - · 68 mm²/s [315 SUS]
 - - - 30 mm²/s [143 SUS]

PWR3

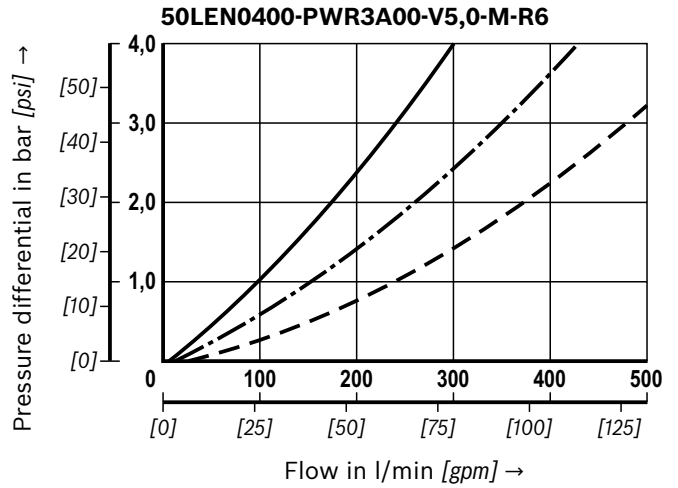
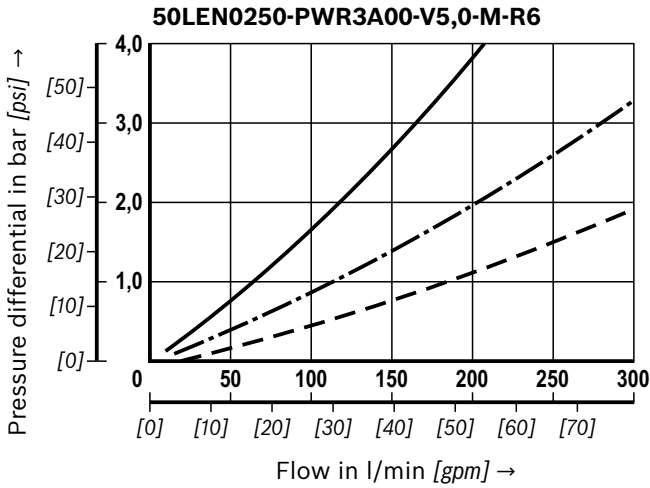

PWR10

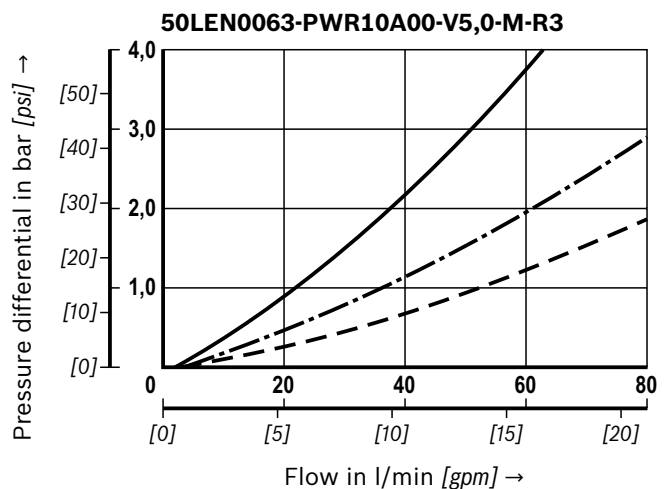
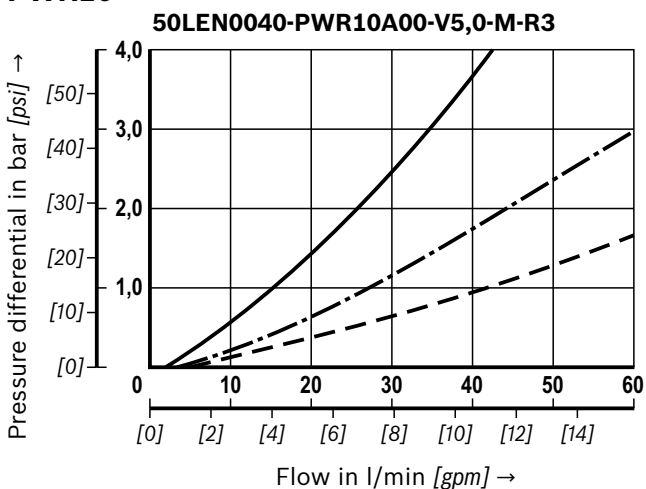

Characteristic curves PWR10

(measured with mineral oil HLP46 according to DIN 51524 at T = 40 °C) [104 °F]

Spec. weight: < 0.9 kg/dm³ Δp -Q-characteristic curves for complete filters recommended initial Δp for design = 1 bar [14.5 psi]

Selection of the perfect filter is made possible by our online "Bosch Rexroth FilterSelect" design software.

Oil viscosity:
 ——— 140 mm²/s [649 SUS]
 - · - · 68 mm²/s [315 SUS]
 - - - 30 mm²/s [143 SUS]

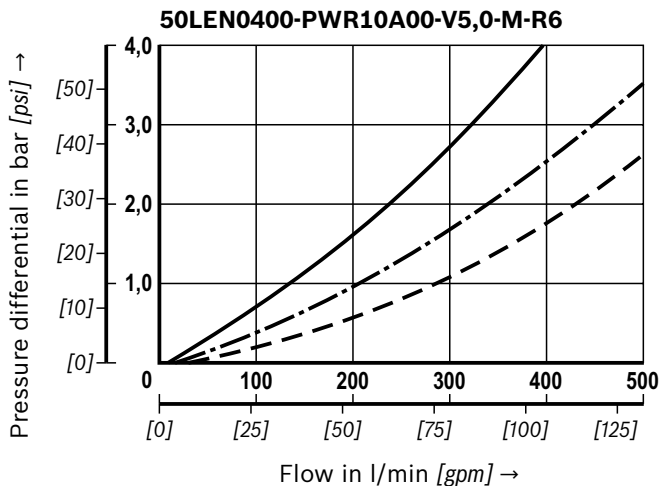
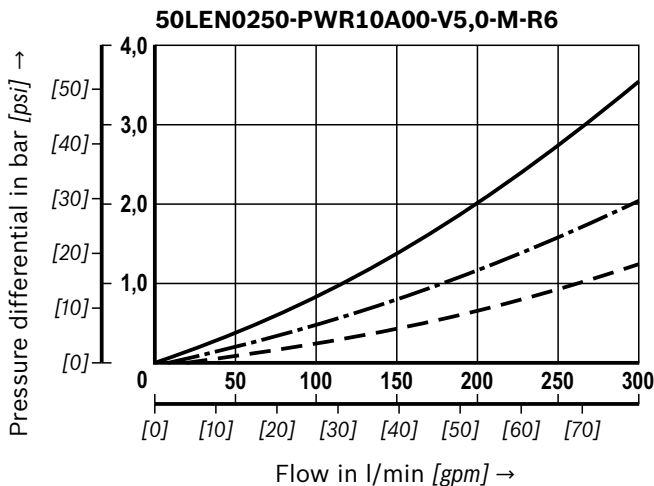
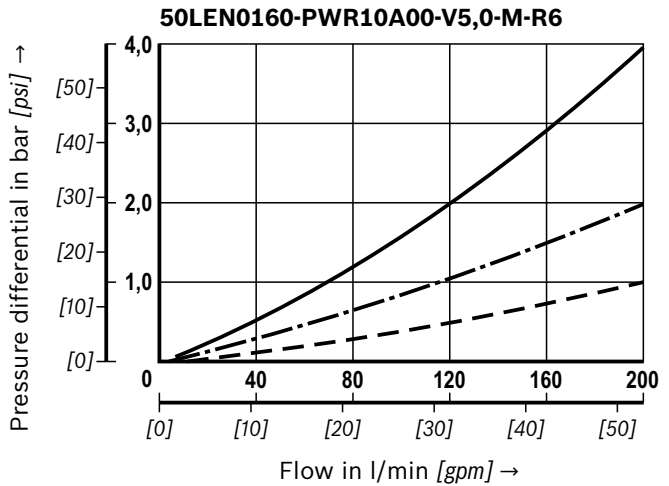
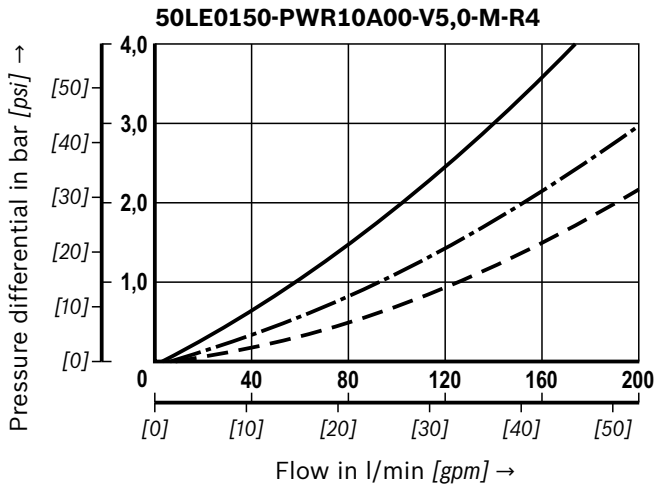
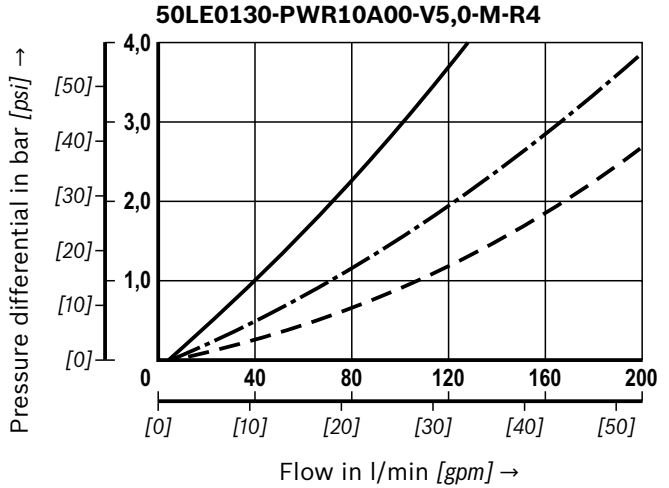
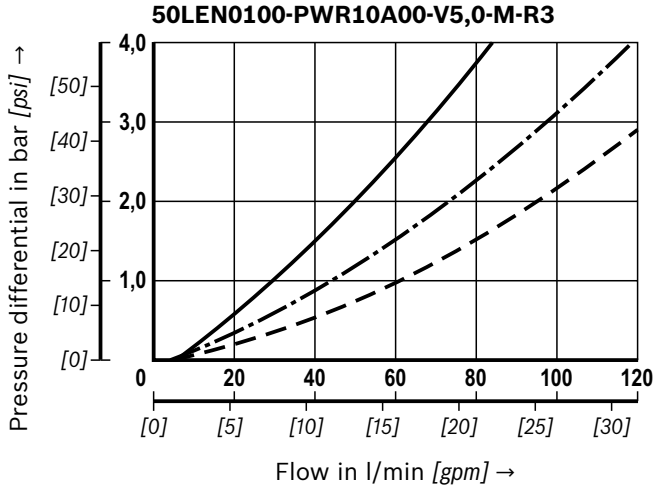

Dimensions: Size 0040 - size 0400

(dimensions in mm [inch])

**Filter housing for filter elements according to DIN 24550
and according to Rexroth standard**

Type 50...	Content in l [US gal]	Weight in kg [lbs]	A1	A2	A3	A4
LEN 0040	0.27 [0.07]	1.05 [2.3]	209 [8.22]		164 [6.46]	
LEN 0063	0.39 [0.1]	1.1 [2.4]	269 [10.59]	87 [3.43]	224 [8.82]	24 [0.94]
LEN 0100	0.58 [0.15]	1.2 [2.6]	359 [14.13]		314 [12.36]	
LE 0130	0.89 [0.23]	1.91 [4.2]	299 [11.77]	98 [3.86]	251 [9.88]	30 [1.18]
LE 0150	1.1 [0.29]	2.06 [4.5]	350 [13.78]		302 [11.89]	
LEN 0160	1.31 [0.35]	3.1 [6.8]	310 [12.20]		255 [10.04]	
LEN 0250	1.89 [0.50]	3.3 [7.3]	400 [15.75]	122 [4.80]	345 [13.58]	35 [1.38]
LEN 0400	2.84 [0.75]	3.8 [8.4]	550 [21.65]		495 [19.49]	

Type 50...	A5	A6	B1	B2	B3	B4	ØB5
LEN 0040							
LEN 0063	139 [5.47]	80 [3.15]	92 [3.62]	27.5 [1.06]	37.5 [1.48]	10 [0.39]	75 [2.95]
LEN 0100							
LE 0130	150 [5.91]	140 [5.51]	122 [4.80]	40 [1.57]	50 [1.97]	14 [0.55]	105 [4.13]
LE 0150							
LEN 0160	174 [6.85]	140 [5.51]	142 [5.59]	50 [1.97]	60 [2.36]	20 [0.79]	125 [4.92]
LEN 0250							
LEN 0400							

Type 50...	ØB6	B7	B8	C1 con- nection	ØC2	ØC3	SW
LEN 0040							
LEN 0063	58 [2.28]	20 [0.79]	41 [1.61]	G 3/4 1 1/16-12 UN-2B	33 [1.30] 41 [1.61]		
LEN 0100							
LE 0130	82 [3.23]	20 [0.79]	56 [2.20]	G 1 1 5/16-12 UN-2B	41 [1.61] 49 [1.93]	32 [1.26]	17 [0.67]
LE 0150							
LEN 0160	102 [4.02]	30 [1.18]	66 [2.60]	G 1 1/2 1 7/8-12 UN-2B	56 [2.20] 65 [2.56]		
LEN 0250							
LEN 0400							

50 LEN 0040-0400

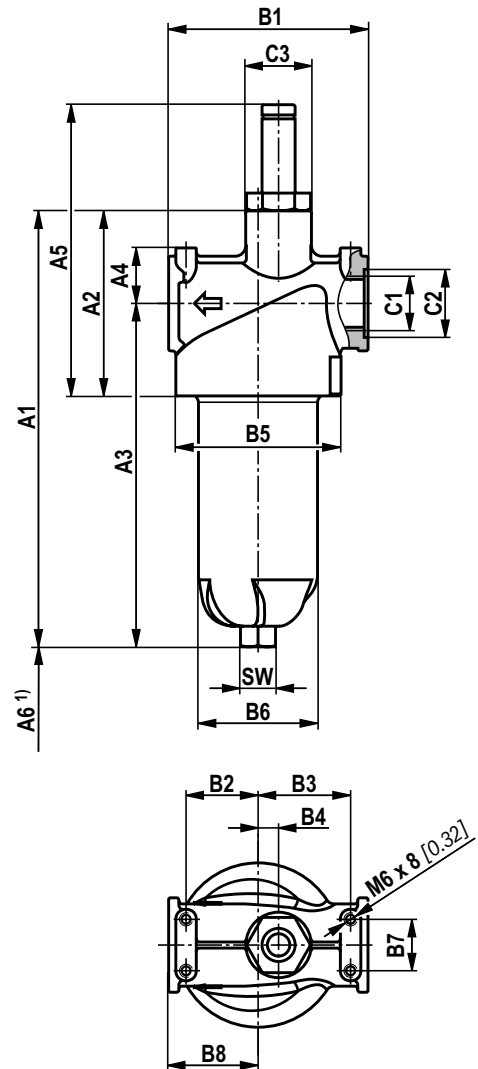

1) Servicing height for filter element exchange

Maintenance indicator
(dimensions in mm [inch])

Pressure differential indicator with mounted switching element M12 x 1

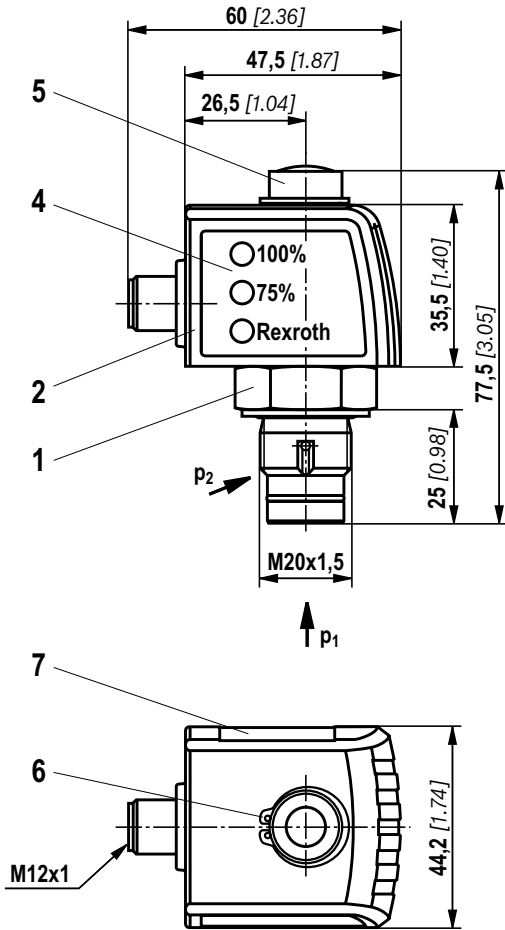

Pressure differential indicator with mounted switching element EN-175301-803

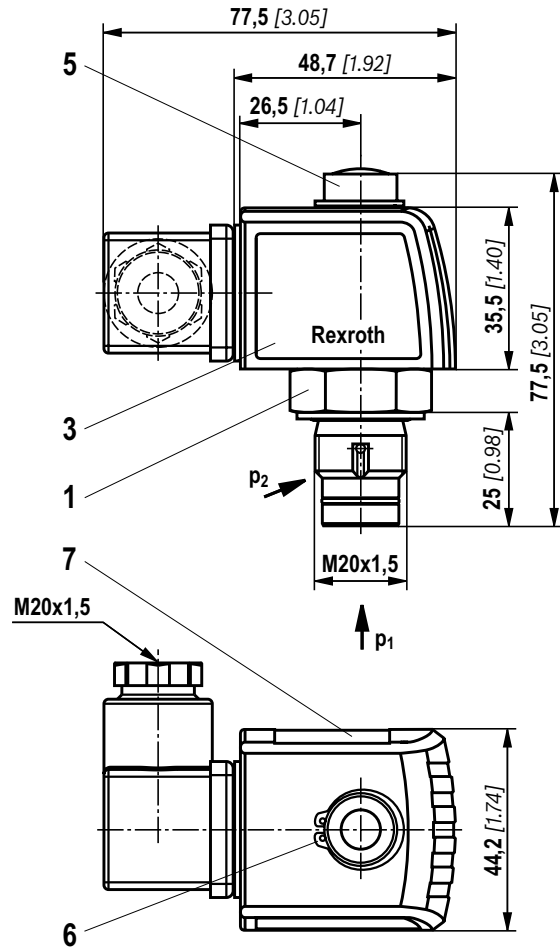

- 1 Mechanical optical maintenance indicator; max. tightening torque $M_{A \max} = 50 \text{ Nm}$ [36.88 lb-ft]
- 2 Switching element with locking ring for electrical maintenance indicator (rotatable by 360°); round plug-in connection M12 x 1, 4-pole
- 3 Switching element with locking ring for electrical maintenance indicator (rotatable by 360°); rectangular plug-in connection EN175301-803
- 4 Housing with three LEDs: 24 V =
green: Stand-by
yellow: Switching point 75%
red: Switching point 100%
- 5 Visual indicator bistable
- 6 Locking ring DIN 471-16 x 1, **material no. R900003923**
- 7 Name plate

Notices:

Representation contains mechanical optical maintenance indicator (1) and electronic switching element (2) (3). Switching elements with increased switching power upon request.

Ordering code spare parts

Filter element

01	02	03	04	05	06
2.			-	-	0

Filter element

01	Design	2.
----	--------	----

Nominal size

02	LEN... (Filter element according to DIN 24550)	0040 0063 0100 0160 0250 0400
	LE... (Filter elements according to Bosch Rexroth standard)	0130 0150

Filter rating in µm

03	Nominal	Stainless steel wire mesh, cleanable	G10 G25 G40 G60 G100
	Nominal	Filter paper, not cleanable	P10 P25
	Absolute (ISO 16889); $\beta_{x(c)} \geq 200$	Non-woven glass fiber media, not cleanable	PWR3 PWR6 PWR10 PWR20

Pressure differential

04	max. admissible pressure differential of the filter element 30 bar [435 psi]	A00
	max. admissible pressure differential of the filter element 330 bar [4786 psi]	B00

Bypass valve

05	Always 0 with filter element	0
----	------------------------------	---

Seal

06	NBR seal	M
	FKM seal	V

Order example:

2.0100 PWR3-A00-0-M

For detailed information on Rexroth filter elements please refer to data sheet 51420.

Preferred program replacement filter element

Replacement filter element 3 micron		Replacement filter element 6 micron		Replacement filter element 10 micron	
R928006645	2.0040 PWR3-A00-0-M	R928006646	2.0040 PWR6-A00-0-M	R928006647	2.0040 PWR10-A00-0-M
R928006699	2.0063 PWR3-A00-0-M	R928006700	2.0063 PWR6-A00-0-M	R928006701	2.0063 PWR10-A00-0-M
R928006753	2.0100 PWR3-A00-0-M	R928006754	2.0100 PWR6-A00-0-M	R928006755	2.0100 PWR10-A00-0-M
R928022274	2.0130 PWR3-A00-0-M	R928022275	2.0130 PWR6-A00-0-M	R928022276	2.0130 PWR10-A00-0-M
R928022283	2.0150 PWR3-A00-0-M	R928022284	2.0150 PWR6-A00-0-M	R928022285	2.0150 PWR10-A00-0-M
R928006807	2.0160 PWR3-A00-0-M	R928006808	2.0160 PWR6-A00-0-M	R928006809	2.0160 PWR10-A00-0-M
R928006861	2.0250 PWR3-A00-0-M	R928006862	2.0250 PWR6-A00-0-M	R928006863	2.0250 PWR10-A00-0-M
R928006915	2.0400 PWR3-A00-0-M	R928006916	2.0400 PWR6-A00-0-M	R928006917	2.0400 PWR10-A00-0-M

Ordering code spare parts

Mechanical optical maintenance indicator

01	02	03	04	05	06
W	O	-	D01	-	-

01	Maintenance indicator	W
----	-----------------------	----------

02	Mechanical optical indicator	O
----	------------------------------	----------

Design

03	Pressure differential, design 01	D01
----	----------------------------------	------------

Switching pressure

04	0.8 bar [12 psi]	0,8
	1.5 bar [22 psi]	1,5
	2.2 bar [32 psi]	2,2
	5.0 bar [72.5 psi]	5,0

Seal

05	NBR seal	M
	FKM seal	V

max. nominal pressure

06	Switching pressure 0.8 bar [11.6 psi], 160 bar [2321 psi]	160
	Switching pressure 1.5 bar [21.8 psi], 160 bar [2321 psi]	160
	Switching pressure 2.2 bar [31.9 psi], 160 bar [2321 psi]	160
	Switching pressure 5.0 bar [72.5 psi], 450 bar [6527 psi]	450

Mechanical optical maintenance indicator

Material no.	Description
R928038779	WO-D01-0.8-M-160
R928038778	WO-D01-0.8-V-160
R928038781	WO-D01-1.5-M-160
R928038780	WO-D01-1.5-V-160
R901025312	WO-D01-2.2-M-160
R901066233	WO-D01-2.2-V-160
R901025313	WO-D01-5,0-M-450
R901066235	WO-D01-5,0-V-450

Ordering code spare parts

Seal kit

01	02	03	04
D	50/110LE		-

01	Seal kit	D
02	Series 50LE and 110LE	50/110LE

Nominal size

03	0040-0100	N0040-0100
	0130-0150	0130-0150
	0160-0400	N0160-0400

Seal

04	NBR seal	M
	FKM seal	V

Seal kit

Material no.	Description
R928046935	D50/110LEN0040-0100-M
R928046936	D50/110LE0130-0150-M
R928046937	D50/110LEN0160-0400-M
R928051951	D50/110LEN0040-0100-V
R928051952	D50/110LE0130-0150-V
R928051953	D50/110LEN0160-0400-V

Assembly, commissioning, maintenance

Installation

The max. operating pressure of the system must not exceed the max. admissible operating pressure of the filter (see type plate).

During assembly of the filter (see also chapter “Tightening torque”), the flow direction (direction arrows) and the required servicing height of the filter element (see chapter “Dimensions”) are to be considered.

Easy filter element exchange is guaranteed in the installation position filter bowl vertically downwards. The maintenance indicator must be arranged in a well visible way.

Remove the plastic plugs in the filter inlet and outlet.

Ensure that the system is assembled without tension stress.

The optional electronic maintenance indicator is connected via the electronic switching element with 1 or 2 switching points, which is attached to the mechanical optical maintenance indicator and held by means of the locking ring.

Commissioning

Commission the system.

Notice:

There is no bleeding provided at the filter.

Maintenance

- ▶ If at operating temperature, the red indicator pin reaches out of the mechanical optical maintenance indicator and/or if the switching process in the electronic switching element is triggered, the filter element is contaminated and needs to be replaced and cleaned respectively.

- ▶ The material number of the corresponding replacement filter element is indicated on the name plate of the complete filter. It must comply with the material number on the filter element.
- ▶ Decommission the system.
- ▶ The operating pressure is to be release on the system side.

Notice:

There is no bleeding provided at the filter.

- ▶ Via the drain screw (from size 0160 fitted by default), the oil on the dirt side can be drained.
- ▶ Screw off the filter bowl.
- ▶ Remove the filter element from the spigot by rotating it slightly.
- ▶ Clean the filter components, if necessary.
- ▶ Check the seals at the filter bowl for damage and renew them, if necessary.
For suitable seal kits refer to chapter “Spare parts”.
- ▶ Filter elements made of wire mesh can be cleaned. The efficiency of the cleaning process depends on the type of dirt and the amount of the pressure differential before the filter element exchange.
If the pressure differential after the filter element exchange exceeds 150% of the value of a brand-new filter element, the filter element made of wire mesh (G...) also needs to be replaced. For detailed cleaning instructions refer to data sheet 51420.
- ▶ Install the new or cleaned filter element on the spigot again by slightly rotating it.
- ▶ The filter is to be assembled in reverse order.
- ▶ The torque specifications (“Tightening torques” chapter) are to be observed.
- ▶ Commission the system.

WARNINGS!

- ▶ Assembly and disassembly only with depressurized system!
- ▶ Tank is under pressure!
- ▶ Maintenance only be specialists.
- ▶ Remove the filter bowl only if it is not under pressure!
- ▶ Do not exchange the maintenance indicator while the filter is under pressure!

- ▶ Functional and safety warranty only applicable when using genuine Bosch Rexroth spare parts!
- ▶ Warranty becomes void if the delivered item is changed by the ordering party or third parties or improperly mounted, installed, maintained, repaired, used or exposed to environmental condition that do not comply with the installation conditions.

Tightening torques

(dimensions in mm [inch])

Mounting

Series 50 ...	LEN0040	LEN0063	LEN0100	LE0130	LE0150	LEN0160	LEN02	LEN0400
Screw/tightening torque with $\mu_{\text{total}} = 0.14$	M6/4.5 Nm \pm 10 %							
Quantity	4							
Recommended property class of screw	8.8							
Minimum screw-in depth	6 mm + 1 mm							

Filter bowl and maintenance indicator

Series 50 ...	LEN0040	LEN0063	LEN0100	LE0130	LE0150	LEN0160	LEN02	LEN0400
Tightening torque filter bowl	30 Nm + 10 Nm							
Tightening torque maintenance indicator	30 Nm							
Tightening torque cubic connector screw switching element EN-175301-803	M3/0.5 Nm							

Directives and standardization

Product validation

Rexroth filters, the filter elements built into them and filter accessories are tested and quality-monitored according to different ISO test standards:

Pressure pulse test	ISO 10771:2015-08
Filtration performance test (multipass test)	ISO 16889:2008-06
Δp (pressure loss) characteristic curves	ISO 3968:2001-12
Compatibility with hydraulic fluid	ISO 2943:1998-11
Collapse pressure test	ISO 2941:2009-04

The development, manufacture and assembly of Rexroth industrial filters and Rexroth filter elements is carried out within the framework of a certified quality management system in accordance with ISO 9001:2000.

Classification according to the Pressure Equipment Directive

The inline filters for hydraulic applications according to 51447 are pressure holding equipment according to article 1, section 2.1.4 of the Pressure Equipment Directive 97/23/EC (PED).

However, on the basis of the exception in article 1, section 3.6 of the PEG, hydraulic filters are exempt from the PED if they are not classified higher than category I (guideline 1/19). They do not receive a CE mark.

Use in potentially explosive areas according to directive 94/9/EC (ATEX)

The inline filters according to 51447 are no equipment or components in the sense of directive 94/9/EC and are not provided with a CE mark. It has been proven with the ignition risk analysis that these inline filters do not have own ignition sources acc. to DIN EN 13463-1:2009.

According to DIN EN 60079-11:2012, the electronic maintenance indicators WE-1SP-M12x1 and WE-1SP-EN175301-803 are simple, electronic operating equipment not having an own voltage source. This simple, electronic operating equipment may - according to DIN

EN 60079-14:2008 - in intrinsically safe electric circuits (Ex ib) be used in systems without marking and certification.

The inline filters and the electronic maintenance indicators described here can be used for the following potentially explosive areas:

	zone suitability	
Gas	1	2
Dust	21	22

Directives and standardization

Complete filter with mech./opt. Maintenance indicator				
Use /assignment			Gas 2G	Dust 2D
Assignment			Ex II 2G c IIC TX	Ex II 2D c IIC TX
Conductivity of the medium	pS/m	min	300	
Dust accumulation		max	–	0.5 mm

Electronic switching element in the intrinsically safe electric circuit				
Use /assignment			Gas 2G	Dust 2D
Assignment			Ex II 2G Ex ib IIB T4 Gb	Ex II 2D Ex ib IIIC T100 °C Db
Perm. intrinsically safe electric circuits			Ex ib IIC, Ex ic IIC	Ex ib IIIC
Technical data			Values only for intrinsically safe electric circuit	
Switching voltage	Ui	max	150 V AC/DC	
Switching current	Ii	max	1.0 A	
Switching power	Pi	max	1.3 W T4 T _{max} 40 °C	750 mW T _{max} 40 °C
		max	1.0 W T4 T _{max} 80 °C	550 mW T _{max} 100 °C
Surface temperature ¹⁾		max	–	100 °C
Inner capacity	Ci		negligible	
Inner inductivity	Li		negligible	
Dust accumulation		max	–	0.5 mm

¹⁾ The temperature depends on the temperature of the medium in the filter and must not exceed the value specified here.

Possible circuit according to DIN EN 60079-14

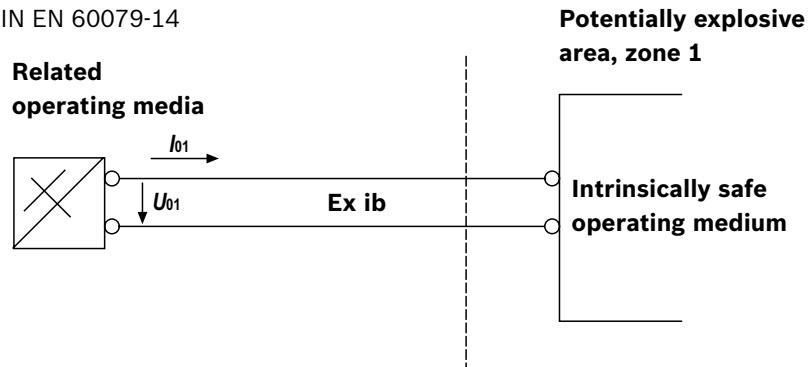

⚠ WARNING!

- ▶ Explosion hazard due to high temperature! The temperature depends on the temperature of the medium in the hydraulic circuit and must not exceed the value specified here. Measures are to be taken so that in the potentially explosive area, the max. admissible ignition temperature is not exceeded.
- ▶ When using the inline filters in accordance with 51447 in potentially explosive areas, appropriate equipotential bonding has to be ensured. The filter is preferably to be earthed via the mounting screws. It has to be

noted in this connection that paintings and oxidic protective layers are not electrically conductive.

- ▶ Maintenance only by specialists, instruction by the machine end-user acc. to DIRECTIVE 1999/92/EC appendix II, section 1.1
- ▶ During filter element exchanges, the packaging material is to be removed from the replacement element outside the potentially explosive area
- ▶ Functional and safety warranty only applicable when using genuine Rexroth spare parts

Bosch Rexroth AG
Werk Ketsch
Hardtwaldstr. 43
68775 Ketsch, Germany
Telefon +49 (0) 62 02 / 603-0
filter-support@boschrexroth.de
www.boschrexroth.de

© This document, as well as the data, specifications and other information set forth in it, are the exclusive property of Bosch Rexroth AG. It may not be reproduced or given to third parties without the consent of Bosch Rexroth AG. The data specified above only serve to describe the product. No statements concerning a certain condition or suitability for a certain application can be derived from our information. The information given does not release the user from the obligation of own judgment and verification. It must be remembered that our products are subject to a natural process of wear and aging.