

Slim Incremental 50-mm-dia. Rotary Encoder

## E6C2-CWZ1X 1024P/R 2M

Rotary Encoder, Incremental, External Diameter: 50 dia., Line-driver output, 1024 P/R, 5 VDC, Phases A/-A/B/-B/Z/-Z, Pre-wired model, 2 m

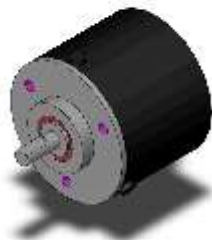

Image

Encoding method	Incremental Shaft model
Resolution	1024 P/R
Output phases	A, -A, B, -B, Z and -Z
Control output	Line driver output
Connection method	Pre-wired models (Cable length: 2 m)

Ratings / Performance

As of July 25, 2024

Categorise		Incremental Shaft model
Diameter		50 mm dia.
Power supply voltage		5 VDC±5% ripple (p-p) 5% max.
Current consumption		160 mA max.
Resolution		1024 P/R
Inrush current		Approx. 9 A (0.3 ms)
Output phases		A, -A, B, -B, Z and -Z
Control output	Output type	Line driver output
	Output voltage	Vo: 2.5 V min. Vs: 0.5 V max.
	Load current	High level (Io): -20 mA Low level (Is): 20 mA
Starting positional point		Equipped
Max. response frequency		100 kHz
Phase difference on output		90±45 ° between A and B (1/4 T ± 1/8 T)
Rise and fall times of output		0.1 µs max. (Cable length: 2 m, Io = -20 mA, Is = 20 mA)
Starting torque		10 mN.m max.
Moment of inertia		1 x 10 <sup>-6</sup> kg.m <sup>2</sup> max.
Shaft loading		Radial: 50 N Thrust: 30 N
Max. permissible rotation		6000 r/min
Ambient temperature		Operating: -10 to 70 °C (with no icing) Storage: -25 to 85 °C (with no icing)
Ambient humidity		Operating: 35 to 85 % (with no condensation) Storage: 35 to 85 % (with no condensation)
Insulation resistance		Between charged parts and the case: 100 MΩ min. (at 500 VDC)

<b>Dielectric strength</b>	Between charged parts and the case: 500 VAC 50/60 Hz 1 min
<b>Vibration resistance</b>	Destruction: 10 to 500 Hz, 2-mm or 150 m/s <sup>2</sup> double amplitude for 11 min 3 times each in X, Y, and Z directions
<b>Shock resistance</b>	Destruction: 1000 m/s <sup>2</sup> for 3 times each in X, Y, and Z directions
<b>Degree of protection</b>	IEC: IP64 Company standard: Oil resistance
<b>Connection method</b>	Pre-wired models (Cable length: 2 m)
<b>Material</b>	Case: Zinc alloy Main Unit: Aluminum Shaft: SUS420J2
<b>Weight</b>	Package: Approx. 400 g
<b>Accessories</b>	Instruction manual

As of July 25, 2024

### Dimensions

As of July 25, 2024

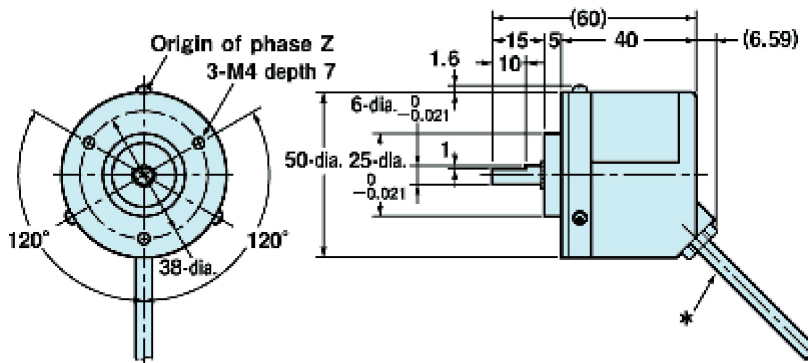

**\*5-dia. Oil-resistant PVC-Insulated shielded cable with 5 conductors (Line driver: 8 conductors) (conductor cross section: 0.2mm<sup>2</sup>, insulator diameter: 1.0mm) Standard length: 2m**

As of July 25, 2024

### Output circuit diagram

As of July 25, 2024

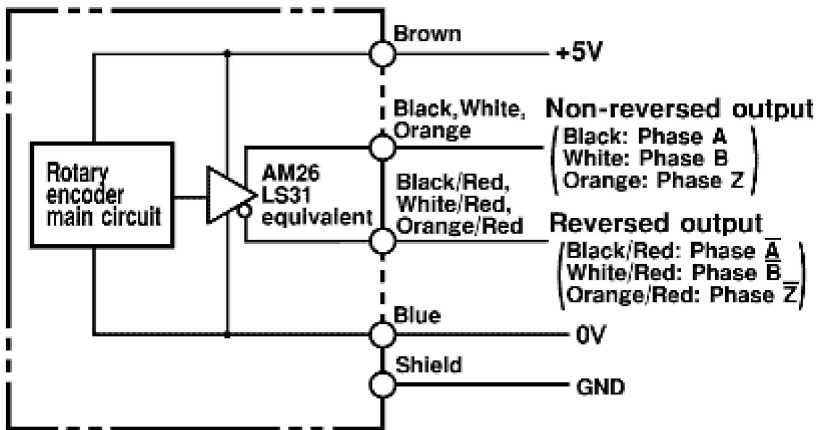

- \*1. The shielded cable outer core is not connected to the inner area or the case.
- 2. Normally, connect GND to 0V or to an external ground.

As of July 25, 2024

Connected specification chart

As of July 25, 2024

Color	Terminal
Brown	Vcc
Black	Phase A
Black/Red stripes	Phase A
White	Phase B
White/Red stripes	Phase B
Orange	Phase Z
Orange/Red stripes	Phase Z
Blue	0V(COMMON)
Shield	GND

\* Receiver: AM26LS32 equivalent

As of July 25, 2024

Timing chart

As of July 25, 2024

## E6C2-CWZ1X Line Driver Output Model

Direction of rotation: CW  
(as viewed from end of shaft)

Direction of rotation: CCW  
(as viewed from end of shaft)

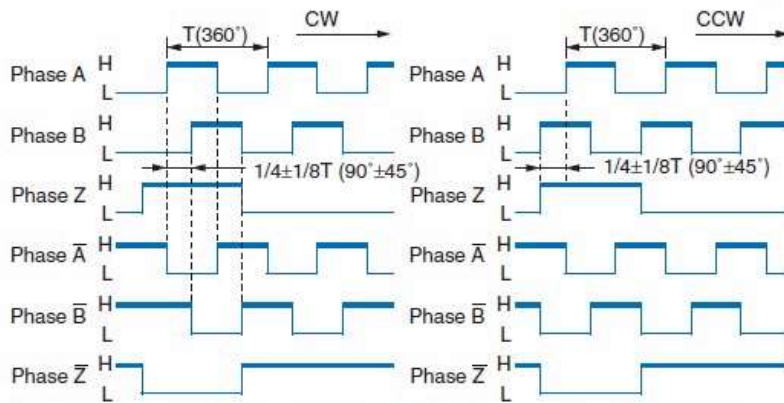

Note: Phase A is  $1/4 T \pm 1/8 T$   
faster than phase B.

Note: Phase A is  $1/4 T \pm 1/8 T$   
slower than phase B.

(“H” and “L” in the diagrams are the output voltage  
levels of phases A, B, and Z.)

As of July 25, 2024