

Slim Incremental 50-mm-dia. Rotary Encoder

## E6C2-CWZ6C 60P/R 2M

Rotary Encoder, Incremental, External Diameter: 50 dia., NPN Open-collector output, 60 P/R, 5 to 24 VDC, Phases A/B/Z, Pre-wired model, 2 m

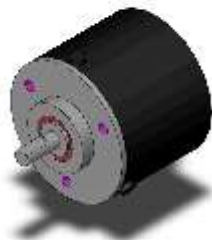

Image

Encoding method	Incremental Shaft model
Resolution	60 P/R
Output phases	A, B and Z
Control output	NPN open collector
Connection method	Pre-wired models (Cable length: 2 m)

Ratings / Performance

As of July 25, 2024

Categorise		Incremental Shaft model
Diameter		50 mm dia.
Power supply voltage		5 to 24 VDC (-5% to +15%) Ripple (p-p) 5% max.
Current consumption		80 mA max.
Resolution		60 P/R
Inrush current		Approx. 9 A (0.3 ms)
Output phases		A, B and Z
Control output	Output type	NPN open collector
	Load power supply voltage	30 V max.DC
	Sink current	35 mA max.
	Residual voltage	0.4 V max. (at sink current 35 mA)
Starting positional point		Equipped
Max. response frequency		100 kHz
Phase difference on output		90±45 ° between A and B (1/4 T ± 1/8 T)
Rise and fall times of output		1 µs max. (Cable length: 2 m, output voltage: 5 V, load resistance: 1 kΩ)
Starting torque		10 mN.m max.
Moment of inertia		3 x 10 <sup>-7</sup> kg.m <sup>2</sup> max.
Shaft loading		Radial: 50 N Thrust: 30 N
Max. permissible rotation		6000 r/min
Protective circuit		Output short-cut protection Power supply reverse polarity protection
Ambient temperature		Operating: -10 to 70 °C (with no icing) Storage: -25 to 85 °C (with no icing)

<b>Ambient humidity</b>	Operating: 35 to 85 % (with no condensation) Storage: 35 to 85 % (with no condensation)
<b>Insulation resistance</b>	Between charged parts and the case: 100 MΩ min. (at 500 VDC)
<b>Dielectric strength</b>	Between charged parts and the case: 500 VAC 50/60 Hz 1 min
<b>Vibration resistance</b>	Destruction: 10 to 500 Hz, 2-mm or 150 m/s <sup>2</sup> double amplitude for 11 min 3 times each in X, Y, and Z directions
<b>Shock resistance</b>	Destruction: 1000 m/s <sup>2</sup> for 3 times each in X, Y, and Z directions
<b>Degree of protection</b>	IEC: IP64 Company standard: Oil resistance
<b>Connection method</b>	Pre-wired models (Cable length: 2 m)
<b>Material</b>	Case: Zinc alloy Main Unit: Aluminum Shaft: SUS420J2
<b>Weight</b>	Package: Approx. 400 g
<b>Accessories</b>	Instruction manual

As of July 25, 2024

### Dimensions

As of July 25, 2024

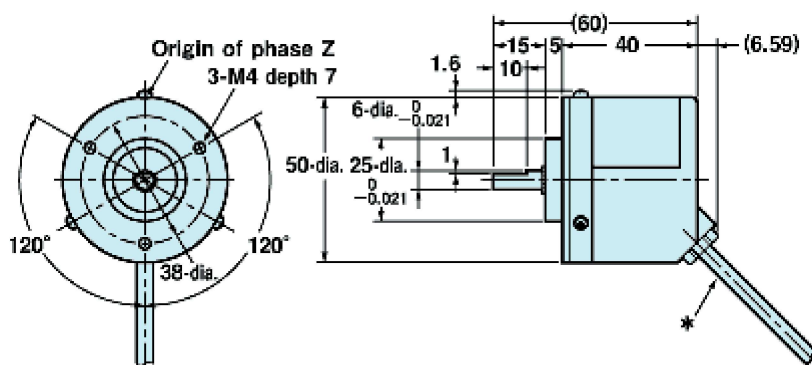

\*5-dia. Oil-resistant PVC-Insulated shielded cable with 5 conductors (Line driver: 8 conductors) (conductor cross section: 0.2mm<sup>2</sup>, Insulator diameter: 1.0mm) Standard length: 2m

As of July 25, 2024

### Output circuit diagram

As of July 25, 2024

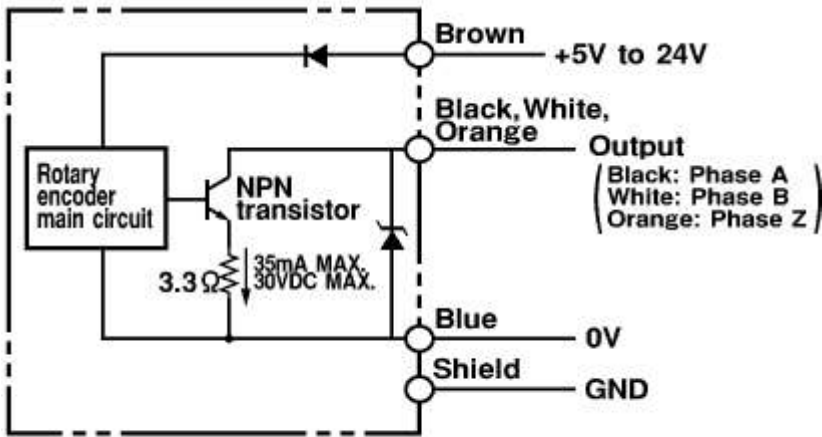

- \*1. The shielded cable outer core is not connected to the inner area or the case.
- 2. Normally, connect GND to 0V or to an external ground.

As of July 25, 2024

Connected specification chart

As of July 25, 2024

Color	Terminal
Brown	Vcc
Black	Phase A
White	Phase B
Orange	Phase Z
Blue	0V(COMMON)
Shield	GND

As of July 25, 2024

Timing chart

As of July 25, 2024

Output phase	Direction of rotation	Output mode
Phase A Phase B Phase Z	<b>CW</b> as viewed from the end of the shaft	<p>Phase A ON OFF</p> <p>Phase B ON OFF</p> <p>Phase Z ON OFF</p> <p><math>T(360^\circ)</math></p> <p>CW</p> <p><math>1/4T \pm 1/8T(90^\circ \pm 45^\circ)</math></p>
Phase A Phase B Phase Z	<b>CCW</b> as viewed from the end of the shaft	<p>Phase A ON OFF</p> <p>Phase B ON OFF</p> <p>Phase Z ON OFF</p> <p><math>T(360^\circ)</math></p> <p>CCW</p> <p><math>1/4T \pm 1/8T(90^\circ \pm 45^\circ)</math></p>

\*CW direction: Phase A is  $1/4 \pm 1/8T$  faster than phase B.  
 CCW direction: Phase A is  $1/4 \pm 1/8T$  slower than phase B.

As of July 25, 2024