

SICK.COM



DATA SHEET

WLG4S-3P3432V

W4
Photoelectric sensors

SICK Sensor Intelligence

PHOTOELECTRIC SENSORS

WLG4S-3P3432V

ORDERING INFORMATION

Type	part no.
WLG4S-3P3432V	1046449

Further device versions and accessories at www.sick.com/W4



Illustration may differ

DETAILED TECHNICAL DATA

FEATURES

Functional principle	Photoelectric retro-reflective sensor	
Functional principle detail	Without reflector minimum distance (autocollimation/coaxial optics)	
Sensing range max.	0 m ... 5 m ¹⁾	
Sensing range	0 m ... 3 m ¹⁾	
Polarisation filter	Yes	
Emitted beam	Light source	PinPoint LED ²⁾
	Type of light	Visible red light
	Light spot size (distance)	Ø 45 mm (1.5 m)
Key LED figures	Wave length	650 nm
Adjustment	Single teach-in button	
Special applications	Hygienic and washdown zones, Detecting transparent objects	
Housing design	Washdown	
AutoAdapt	✓	

¹⁾ Reflector PL80A.

²⁾ Average service life: 100,000 h at T_u = +25 °C.

SAFETY-RELATED PARAMETERS

MTTF _D	1,215 years
DC _{avg}	0 %

T_M (mission time)	20 years
----------------------	----------

ELECTRONICS

Supply voltage U_B	10 V DC ... 30 V DC ¹⁾										
Ripple	< 5 V _{pp} ²⁾										
Current consumption	30 mA ³⁾										
Protection class	III										
Digital output	<table border="0"> <tr> <td style="text-align: right;">Type</td> <td>PNP</td> </tr> <tr> <td style="text-align: right;">Switching mode</td> <td>Light/dark switching</td> </tr> <tr> <td style="text-align: right;">Output current I_{max}</td> <td>≤ 100 mA</td> </tr> <tr> <td style="text-align: right;">Response time</td> <td>< 0.5 ms ⁴⁾</td> </tr> <tr> <td style="text-align: right;">Switching frequency</td> <td>1,000 Hz ⁵⁾</td> </tr> </table>	Type	PNP	Switching mode	Light/dark switching	Output current I_{max}	≤ 100 mA	Response time	< 0.5 ms ⁴⁾	Switching frequency	1,000 Hz ⁵⁾
Type	PNP										
Switching mode	Light/dark switching										
Output current I_{max}	≤ 100 mA										
Response time	< 0.5 ms ⁴⁾										
Switching frequency	1,000 Hz ⁵⁾										
Attenuation along light beam	> 8 %										
Output function	Complementary										
Circuit protection	A ⁶⁾ B ⁷⁾ C ⁸⁾										

¹⁾ Limit values, reverse-polarity protected, operation in short-circuit protected network: max. 8 A.

²⁾ May not fall below or exceed U_V tolerances.

³⁾ Without load.

⁴⁾ Signal transit time with resistive load.

⁵⁾ With light/dark ratio 1:1.

⁶⁾ A = V_B connections reverse-polarity protected.

⁷⁾ B = inputs and output reverse-polarity protected.

⁸⁾ C = interference suppression.

MECHANICS

Housing	Rectangular						
Design detail	Slim						
Dimensions (W x H x D)	15.25 mm x 49.2 mm x 22.2 mm						
Connection	Cable with M12 male connector, 4-pin ^{1) 2)}						
Connection detail	<table border="0"> <tr> <td style="text-align: right;">Length of cable (L)</td> <td>150 mm ²⁾</td> </tr> </table>	Length of cable (L)	150 mm ²⁾				
Length of cable (L)	150 mm ²⁾						
Material	<table border="0"> <tr> <td style="text-align: right;">Housing</td> <td>Metal, Stainless steel V4A (1.4404, 316L)</td> </tr> <tr> <td style="text-align: right;">Front screen</td> <td>Plastic, PMMA</td> </tr> <tr> <td style="text-align: right;">Cable</td> <td>Plastic, PVC</td> </tr> </table>	Housing	Metal, Stainless steel V4A (1.4404, 316L)	Front screen	Plastic, PMMA	Cable	Plastic, PVC
Housing	Metal, Stainless steel V4A (1.4404, 316L)						
Front screen	Plastic, PMMA						
Cable	Plastic, PVC						
Weight	60 g						

¹⁾ Max. tightening torque: 0.7 Nm.

²⁾ Do not bend below 0 °C.

AMBIENT DATA

Enclosure rating	IP66 IP67 IP68 IP69K
------------------	-------------------------------

¹⁾ At $UV \leq 24$ V and $IA < 30$ mA.

PHOTOELECTRIC SENSORS - WLG4S-3P3432V

Ambient operating temperature	-30 °C ... +60 °C ¹⁾
Ambient temperature, storage	-30 °C ... +75 °C
UL File No.	NRKH.E181493 & NRKH7.E181493

¹⁾ At UV ≤ 24 V and IA < 30 mA.

CERTIFICATES

EU declaration of conformity	✓
UK declaration of conformity	✓
ACMA declaration of conformity	✓
Moroccan declaration of conformity	✓
China RoHS	✓
China Compulsory Product Certification (CCC) exempt	✓
ECOLAB certificate	✓
Photobiological safety (DIN EN 62471) certificate	✓

CONNECTION DIAGRAM CD-083

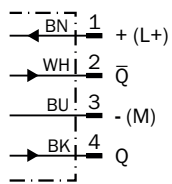

CHARACTERISTIC CURVE WL4S-3, WLG4S-3, 5 M

Operating reserve

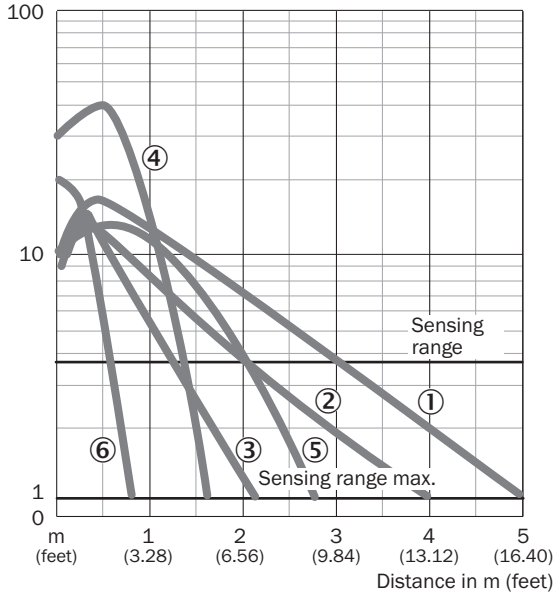

- ① Reflector PL80A
- ② Reflector PL40A
- ③ Reflector PL20A
- ④ PL10F reflector
- ⑤ Reflector P250 CHEM
- ⑥ Reflective tape REF-IRF-56

SENSING RANGE DIAGRAM WL4S-3, WLG4S-3, 5 M

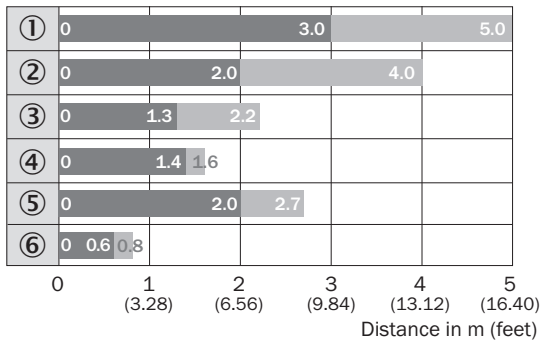

■ Sensing range ■ Sensing range max.

- ① Reflector PL80A
- ② Reflector PL40A
- ③ Reflector PL20A
- ④ PL10F reflector
- ⑤ Reflector P250 CHEM
- ⑥ Reflective tape REF-IRF-56

DIMENSIONAL DRAWING WL4S-3V, WLG4S-3V, WITH SINGLE TEACH-IN BUTTON

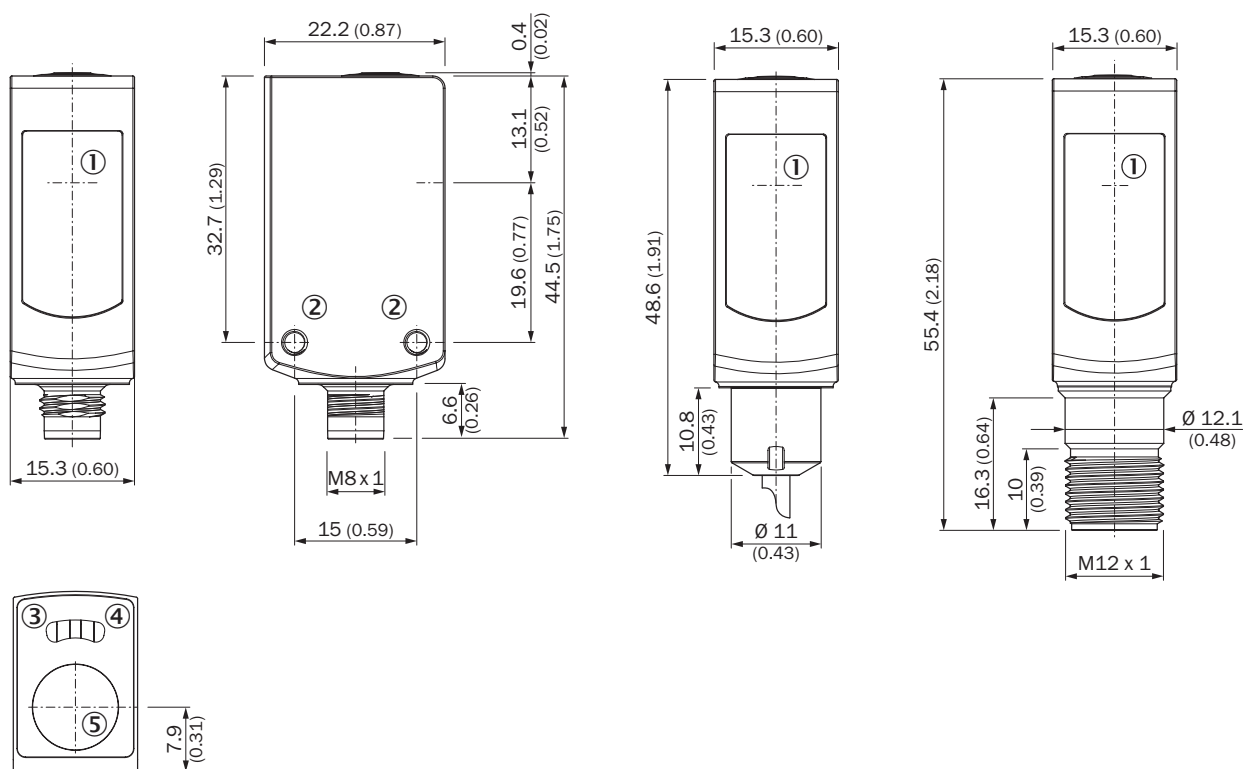

Dimensions in mm (inch)

- ① Center of optical axis
- ② Threaded mounting hole M3
- ③ LED indicator yellow: Status of received light beam
- ④ LED indicator green: Supply voltage active
- ⑤ Teach-in button

Further information as well as suitable accessories, example applications and downloads such as CAD dimensional models, operating instructions and software can be found at www.sick.com/1046449



SICK AG
WALDKIRCH
GERMANY
SICK.COM

SICK AT A GLANCE

SICK is a leading global technology company for intelligent sensors and integrated solutions in industrial automation. Our technologies set benchmarks, making your industrial processes more efficient, safer and more sustainable – both in logistics and manufacturing operations.

SICK combines sensor intelligence with industry expertise and certified consulting services. We provide the ideal foundation for scalable as well as tailor-made automation solutions and create added value along the entire value chain. Our close partnerships with our customers are more than just a promise: Together, we optimize productivity, improve quality, protect health and safety, and help build a sustainable future. All with empathy and trust.

Since 1946, we have been developing innovative technologies with passion and a pioneering spirit. With a global network in around 40 countries, SICK has a global presence and is always close by. The company's headquarters are located in Waldkirch near Freiburg, Germany. Our customers benefit from our understanding of both local and global requirements, which enables us to deliver tailor-made solutions

SICK
Sensor Intelligence